

1

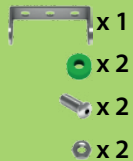

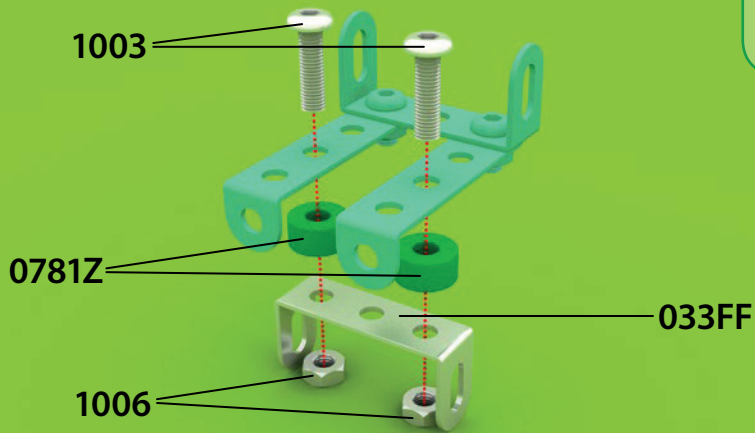

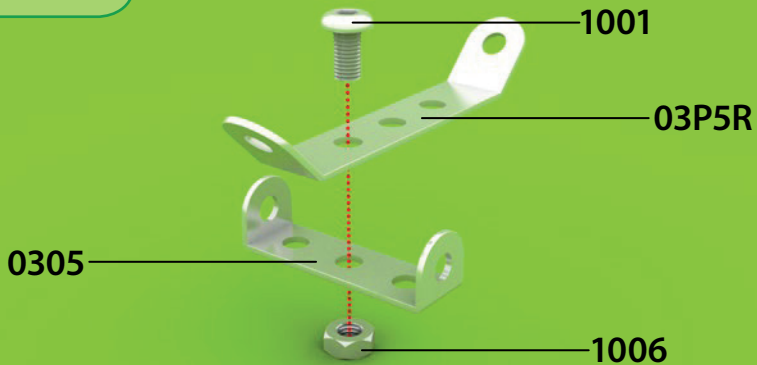

1001

1006

033FF

4

 x 1

 x 1

1001

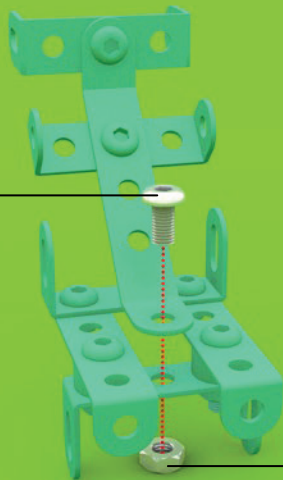

1006

5

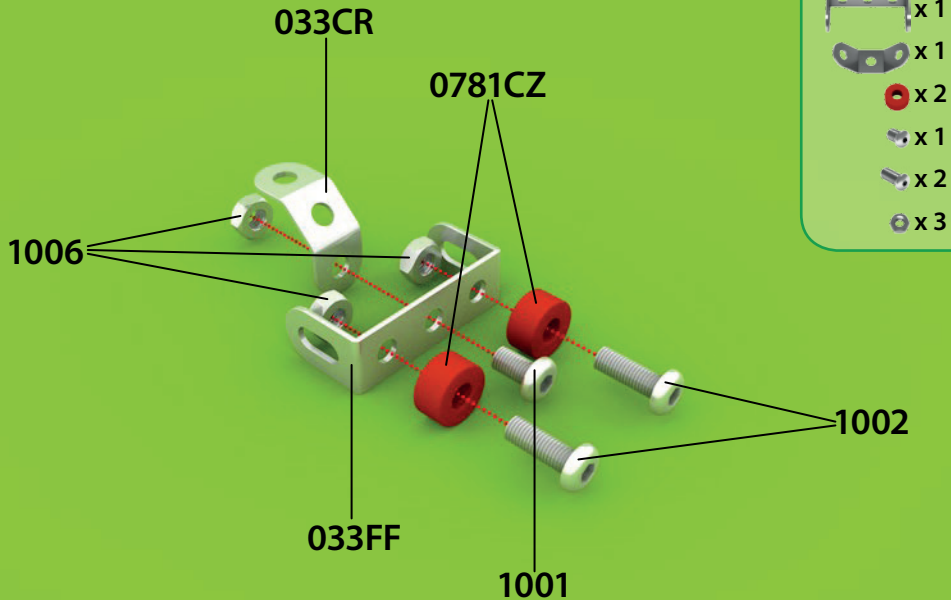

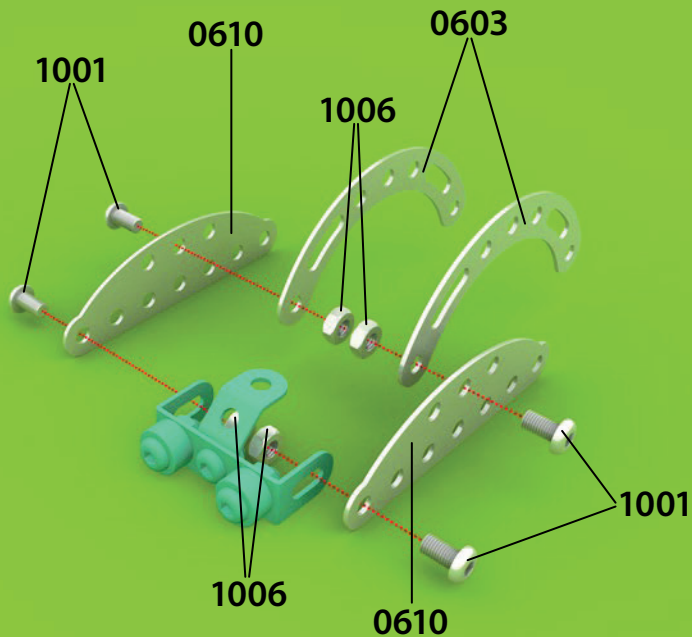

 x 2

 x 2

1006

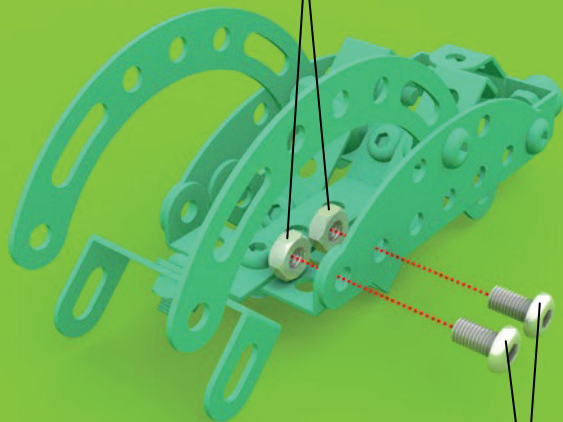

1001

 x 2

 x 2

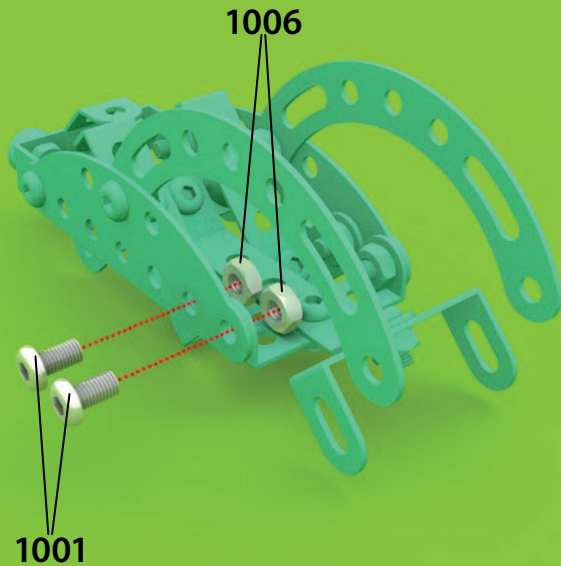

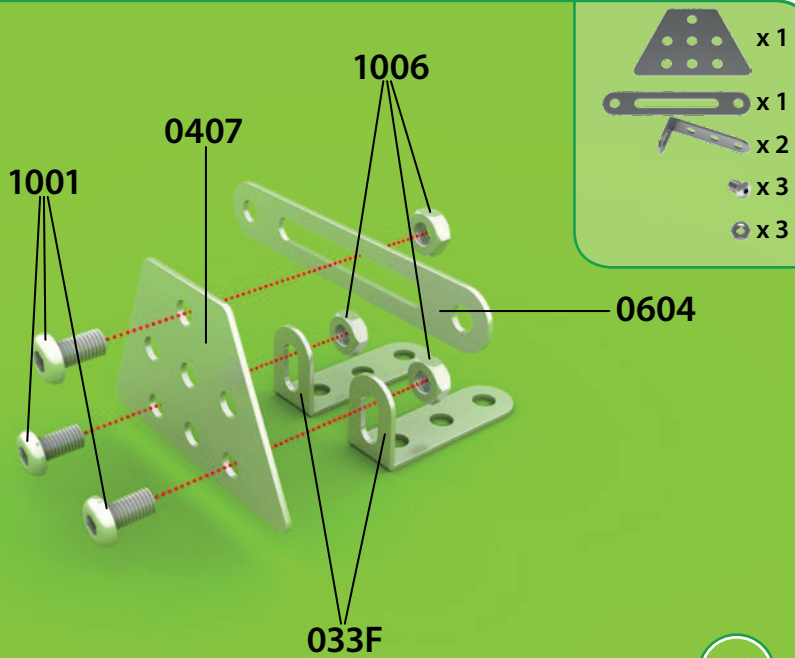

 x 2

 x 2

 x 4

 x 4

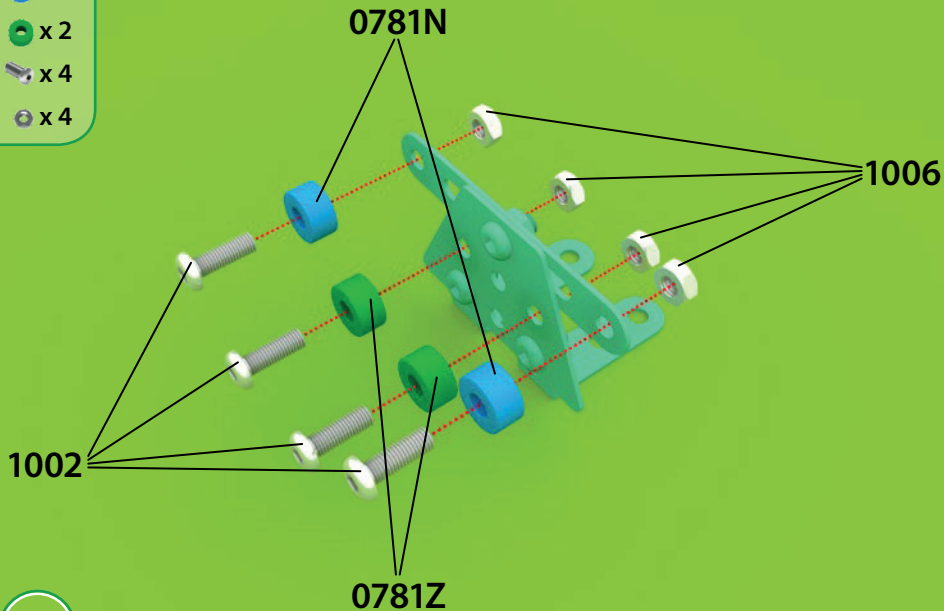

 x 2

 x 2

 x 2

0781Z

1003

1006

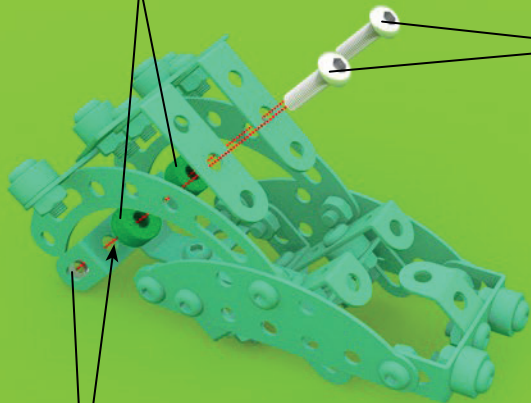



x 2



x 3



x 1



x 1

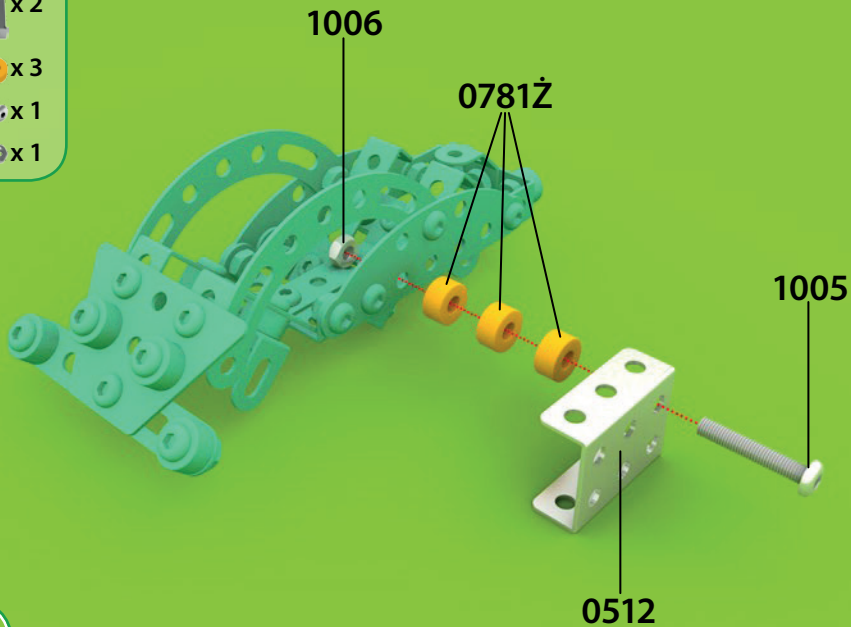

1005

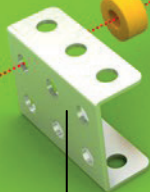

0512

0781Ž



1006



x 2



x 3



x 1



x 1



x 1



x 6



x 2



x 4

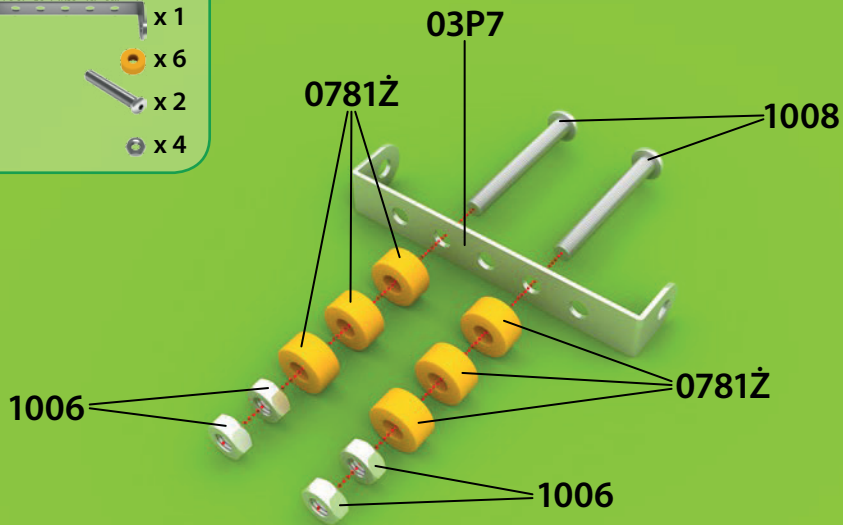

-  x 2
-  x 2
-  x 2

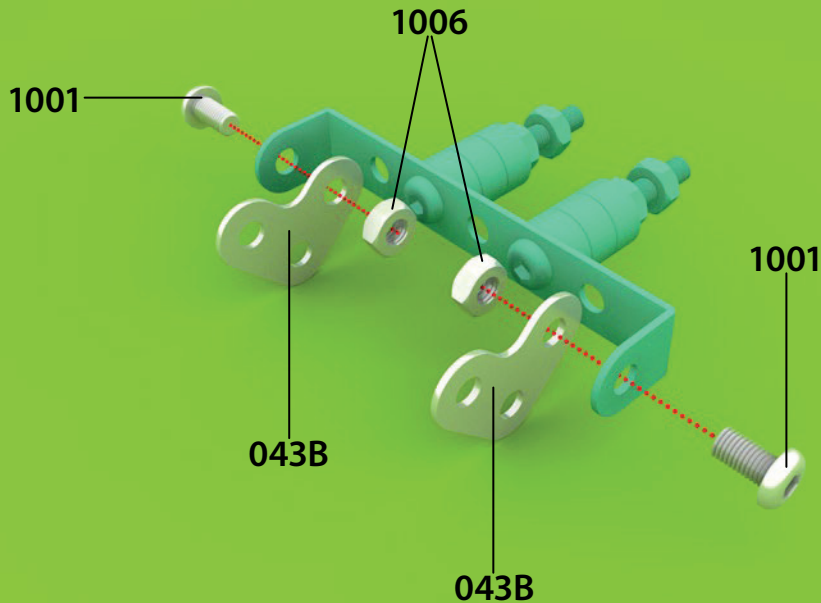



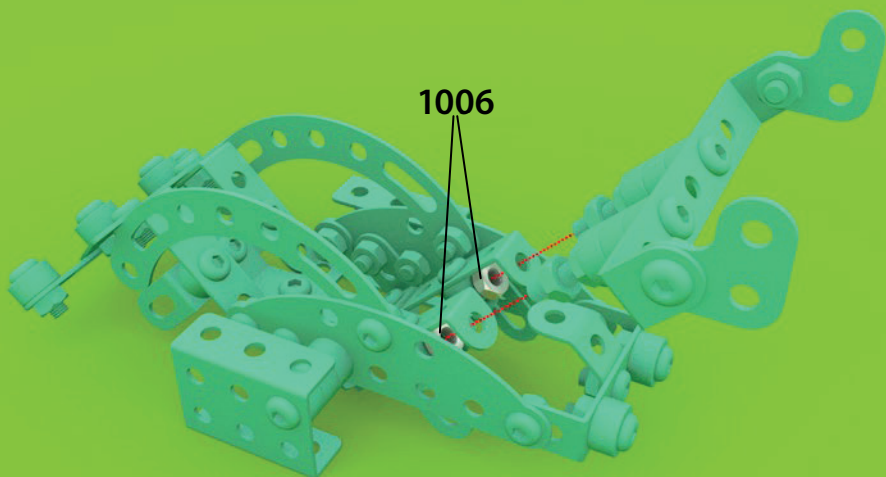

x2

1006





-  x 1
-  x 1
-  x 1
-  x 1

03F1

1001

047DW

1006



x 2



x 1



x 1



x 1



x 2

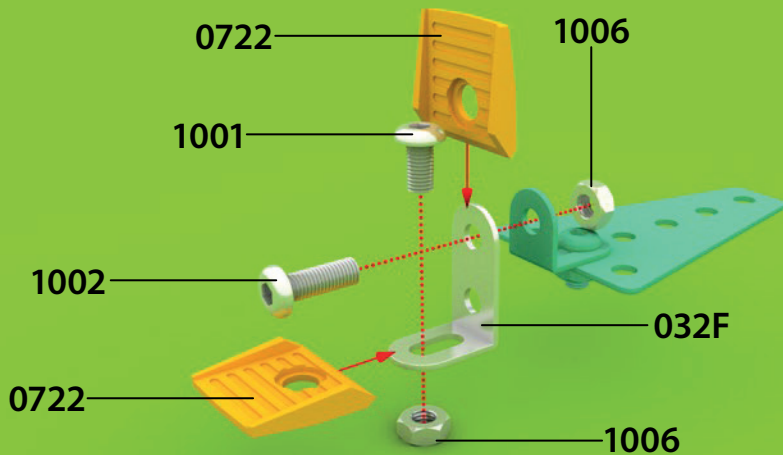

 x 1

 x 1

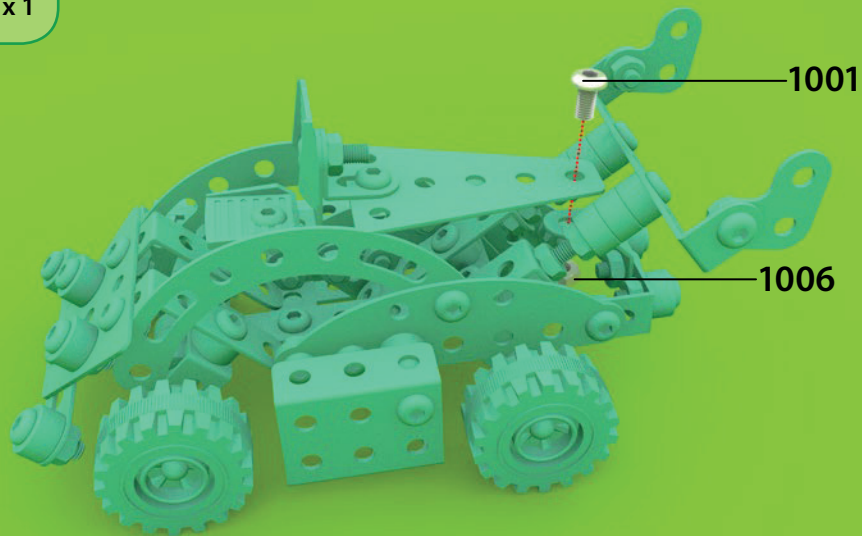

- x 1
- x 1
- x 1
- x 1

1001

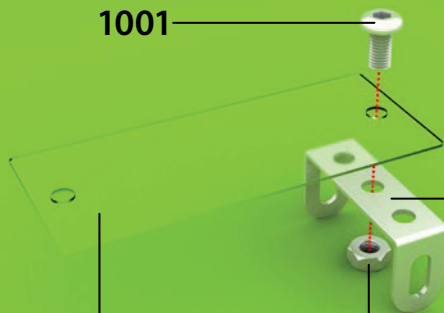

033FF

1102

1006

 x 2

 x 2

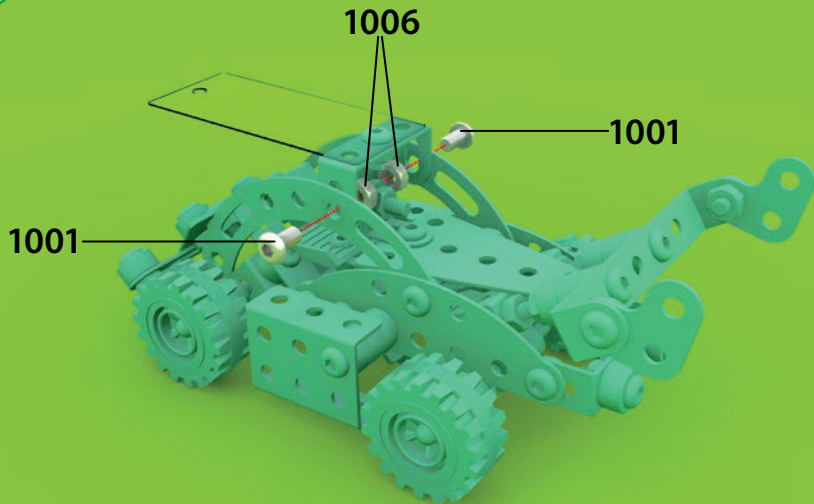

x 1

x 1

x 1

1003

0781B

1006

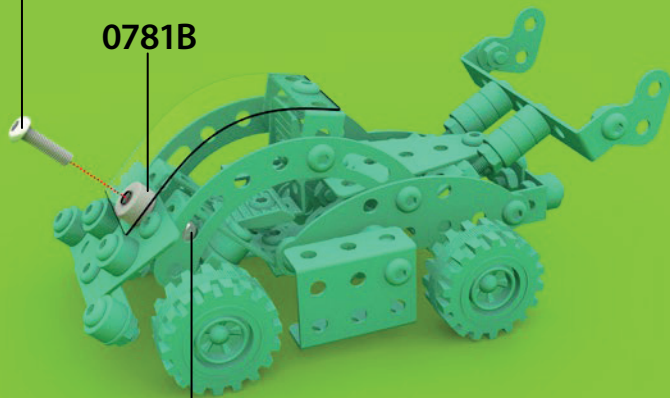





Spis elementów do montażu:

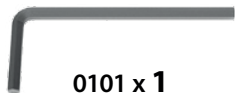

0101 x 1

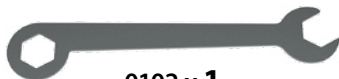

0102 x 1

M4 - 6mm



1001 x 25

M4 - 10mm



1002 x 7

M4 - 12mm



1003 x 5

M4 - 20mm



1005 x 2

M4 - 30mm



1008 x 2



1006 x 45



1007 x 39



03F1 x 1



032F x 1



033F x 2



0341 x 2



03P5R x 1



033CR x 1



0305 x 1



033FF x 5



03P7 x 1



043B x 2

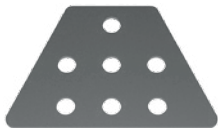

0407 x 1

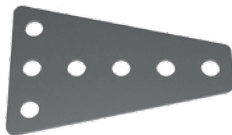

047DW x 1



0512 x 2



0603 x 2



0604 x 1

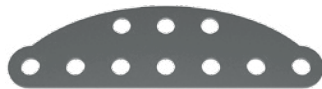

0610 x 2



0906 x 2



0704 x 4



0714 x 4

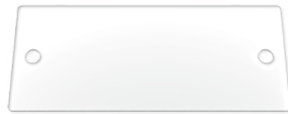

1102 x 1



0722x 2



0781Z x 26



0781Z x 6



0781CZ x 2



0781B x 1



0781N x 2

PL: Ostrzeżenia! Nieodpowiednie dla dzieci w wieku poniżej 3 lat. Zestaw zawiera małe elementy – niebezpieczeństwo zakrztuszenia. Prosimy zachować opakowanie ze względu na podane informacje. **EN:** Warnings! Unsuitable for children under the age of 3. Contains small parts – choking hazard. Keep the box for future reference. **DE:** Achtung! Nicht für Kinder unter 3 Jahren geeignet. Enthält kleine Teile, die verschluckt werden können – Erstickungsgefahr. Verpackung für spätere Rückfragen aufbewahren. **FR:** Attention! Ne convient pas aux enfants de moins de 3 ans. Contient des petits éléments pouvant être avalés et engendrer un risque d'étouffement. Documentation à lire et à conserver pour consultation ultérieure. **ES:** ¡Advertencia! No recomendable para niños de 3 años o menores. Peligro de asfixia – piezas pequeñas. Conserve la caja para futuras referencias. **NL:** Waarschuwing! Niet geschikt voor kinderen jonger dan drie jaar. Bevat kleine onderdelen – verstikkingsgevaar opleveren. Bewaar de verpakking, er staat belangrijke informatie op. **CZ:** Upozornění! Nevhodné pro děti do 3 let. Balení obsahuje malé dílky – nebezpečí udušení. Zachovejte prosím obal ze vzhledu na uvedené informace. **SK:** Upozornenia! Nevhodné pre deti vo veku do 3 rokov. Súprava obsahuje malé časti – hrozí nebezpečenstvo udusenía. Obal uschovajte vzhľadom na dôležité informácie, ktoré sa na ňom nachádzajú.

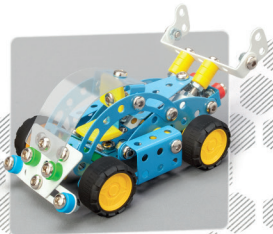
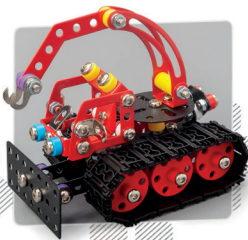
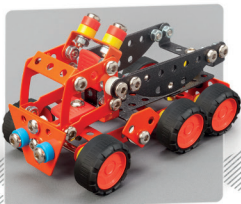
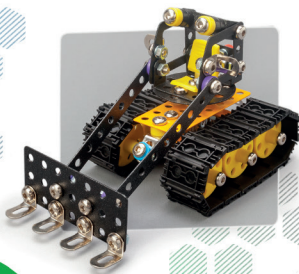

2810



www.alexander.com.pl